

CTB-TYPE 1

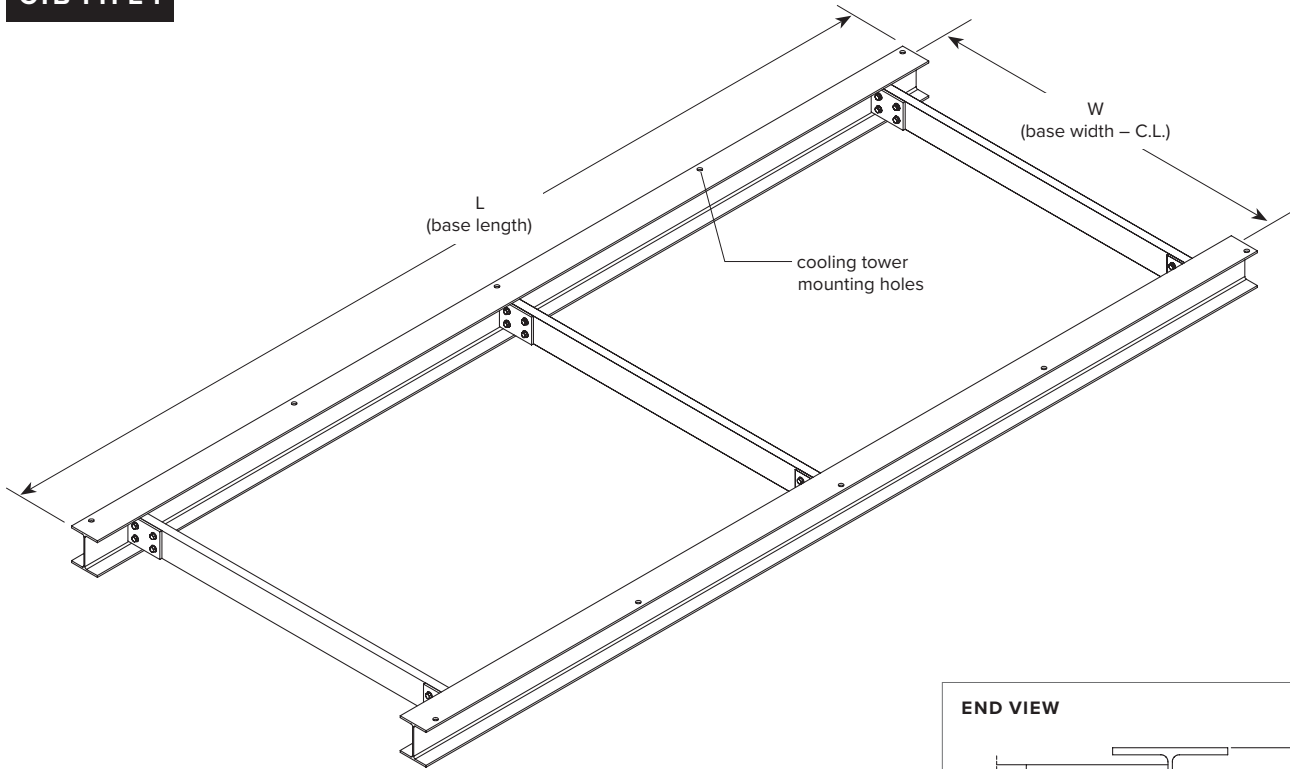

END VIEW

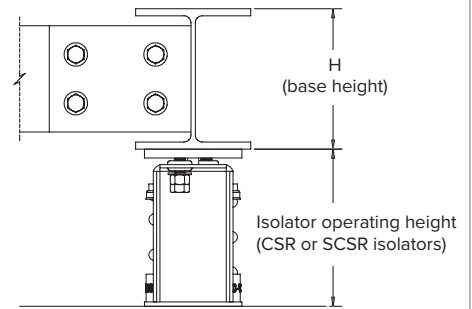

STANDARD OPTIONS (not shown in diagram)

- Special finish
- Hot-dip galvanized
- Epoxy paint
- Enamel paint

NOTES

- The diagram shown is for reference only. Actual product may vary in appearance depending on the requirements of the cooling tower supported.
- This datasheet is not intended for final submittal purposes
- Bases less than 8 ft. wide may be designed as one piece to reduce site assembly time.

Equipment			Base Dimensions and Weight				Isolation	
Manufacturer	Model	Operating Weight (lb)	L (in)	W (in)	H (in)	Base Weight (lb)	Isolator Nominal Deflection (in)	Total Operating Weight (lb)

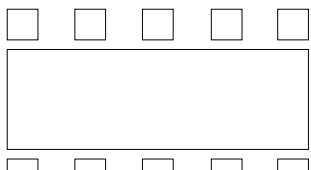
Project:			Plan view of mount locations: 				1:	6:
Customer:							2:	7:
Consultant:							3:	8:
Dwg No.:	Rev:	Drawn by:					4:	9:
V-A Project Manager:							5:	10:
Tag:		Date:	QTY of sets required:					
Comments:			Equipment:					