

tel: 416-291-7371 1-800-565-8401
fax: 416-291-8049 1-888-811-2264

web: www.vibro-acoustics.com
eml: info@vibro-acoustics.com

File No.: DS-TCIB-002

Date: 26 Sep 2013

Supersedes: DS-TCIB-001

Date: 17 May 2013

STANDARD OPTIONS (not shown in diagram)

- Motor slide rail support
- Equipment bolting template
- 18 GA bottom liner
- Special finish
 - Hot-dip galvanized
 - Epoxy paint
 - Enamel paint

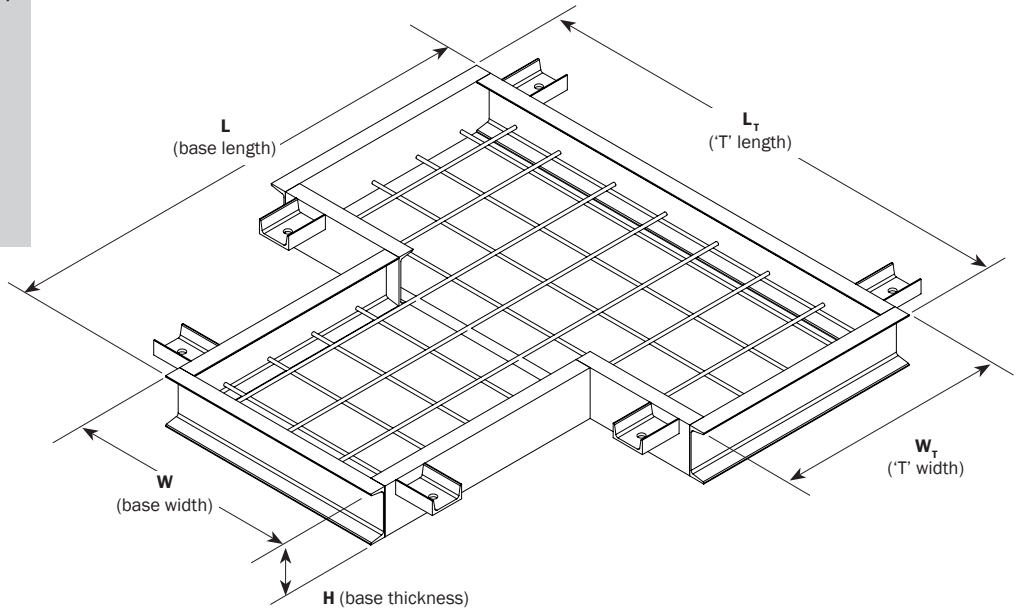

Base Thickness	Flange Width
in (mm)	in (mm)
6" (152)	1 7/8 (48)
8" (203)	2 1/4 (57)
10" (254)	2 5/8 (67)
12" (305)	3 (76)

Custom base thicknesses available upon request

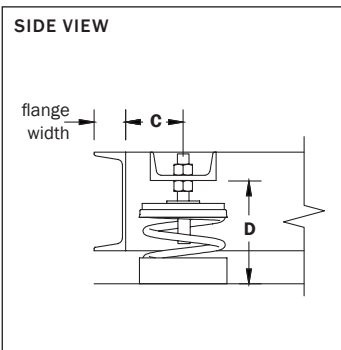
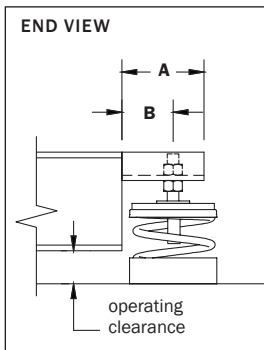

Corner bracket shown with FS isolator. See the table on the right for standard dimensions for different isolators.

Isolator	Base Thickness (inches)	DIMENSIONS				
		Operating Clearance in (mm)	A in (mm)	B in (mm)	C in (mm)	D in (mm)
FS-SA	6", 8", 10", 12"	1 1/2 (38)	3 1/2 (89)	2 1/8 (54)	3 (76)	5 (127)
FS-1A	6"	2 (51)	5 1/2 (140)	3 5/8 (92)	3 1/2 (89)	6 1/4 (159)
	8", 10", 12"	1 1/2 (38)				6 1/2 (165)
FS-2A	6"	2 (51)	5 1/2 (140)	3 5/8 (92)	3 1/2 (89)	8 (203)
	8", 10", 12"					7 7/8 (200)
FS-3A	6", 8"	3 (76)	5 1/2 (140)	3 5/8 (92)	3 1/2 (89)	9 (229)
	10", 12"					9 3/4 (248)
SFS-2N	6", 8", 10", 12"	2 1/2 (64)	5 1/2 (140)	3 5/8 (92)	3 1/2 (89)	8 1/2 (216)
SFS-SA	6", 8", 10", 12"	2 (51)	3 1/2 (89)	2 1/8 (54)	3 (76)	6 1/2 (165)
SFS-1A	8", 10", 12"	2 1/2 (64)	7 1/4 (184)	5 3/8 (136)	5 (127)	8 3/4 (222)
SFS-2A						

Equipment			Base Dimensions and Weight				Isolation	
Manufacturer	Model	Operating Weight (lb)	L (in)	W (in)	H (in)	Base Weight (lb)	Isolator Nominal Deflection (in)	Total Operating Weight (lb)
			L _T (in)	W _T (in)				

Project:	plan view of mount locations		1:	6:		
Customer:			2:	7:		
Consultant:			3:	8:		
Dwg No.:			Rev:	Drawn by:	4:	9:
V-A Project Manager:			QTY of sets required:		5:	10:
TAG:	EQUIPMENT:					
COMMENTS:				DATE:		