

tel: 416-291-7371 1-800-565-8401  
fax: 416-291-8049 1-888-811-2264

web: www.vibro-acoustics.com  
eml: info@vibro-acoustics.com

File No.: INS-AHCS-001  
Supersedes: New

Date: 25 Nov 2010  
Date: New

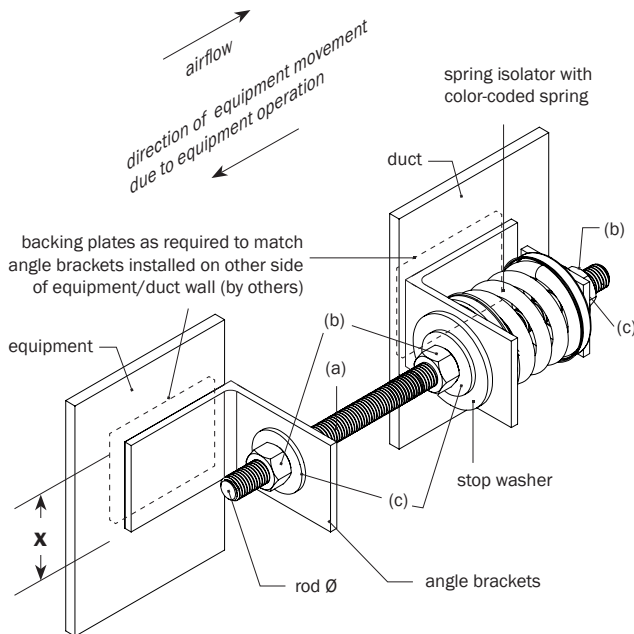

- (a) 15" (381 mm) long threaded rod
- (b) Full hex nuts (6 per isolator)
- (c) USS washer (5 per isolator)

**PLAN VIEW DETAIL**

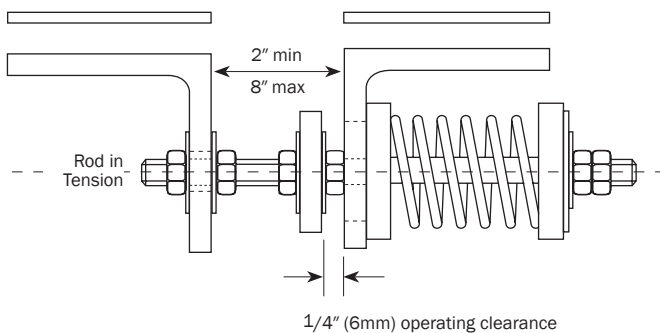

**INSTRUCTIONS**

1. Ensure that the bracket mounting locations are structurally sound for the installation of these thrust restraints.
2. Pair of thrust restraints at height shown on submittal drawings, using color-coded springs for identification.
3. On unit start-up, check to ensure that the 1/4" (6 mm) operating clearance is present. If clearance is insufficient, turn adjustment nut counterclockwise until the clearance is correct. If clearance is greater than 1/4" (6 mm) then adjust nut should be turned clockwise until clearance is correct. Adjust snubbers equally on both sides of unit.