

tel: 416-291-7371 1-800-565-8401 web: www.vibro-acoustics.com
fax: 416-291-8049 1-888-811-2264 eml: info@vibro-acoustics.com

File No.: INS-CSR-H-002 Date: 8 Sep 2020
Supersedes: INS-CSR-H-001 Date: 15 Apr 2014

INSTRUCTIONS

1. Properly locate each isolator as per the submittal drawing using the isolator model and spring color(s) as identification.
2. Elevate equipment enough to place spring isolators underneath and lower equipment onto isolators. Position the isolators to ensure load is centered on equipment support plate and that, if used, steel beam webs are located directly above the center rod. If isolators are to be bolted to the supporting structure locate bolt hole locations and make preparations as appropriate (drill holes and install anchor bolts). Leave shipping spacers in place.

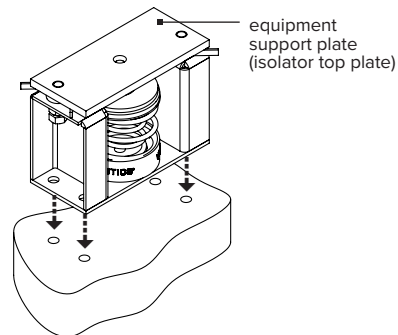

3. Attach equipment to equipment support plate (For example, by welding) Use caution while welding galvanized housing. Touch up afterwards as needed.
4. Piping and equipment must be at operating weight before final adjustment can begin.

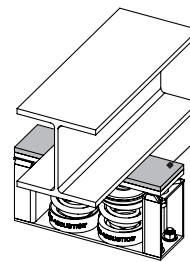
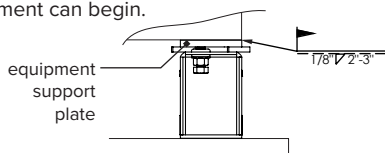

CAUTION: If less than 80% of the top plate is covered by the supported equipment, use an additional plate on top of the isolator.

Extra caution (additional plate under the isolator) should be taken when there are pads under the isolator.

5. Back off the hold-down nuts until it locks with the limit bolt.

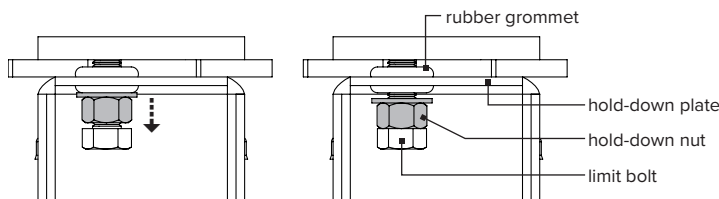

6. Turn spring leveling bolt counter-clockwise 4 complete turns on each isolator as shown in the sequence below. Repeat this pattern until the top plate just lifts off the spacers on all isolators.

Applying grease or WD-40 to leveling bolts thread can help with leveling process.

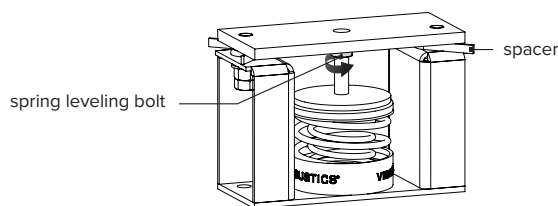

Isolator adjustment sequence example

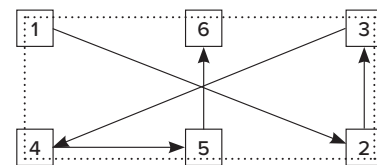

7. Remove all spacer pieces as soon as the top plate is lifted off the spacers. The spacers should slide out with no effort.

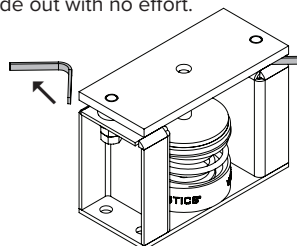

8. Ensure the restraint limit bolt is not touching the hold-down plate but is in the center of the hole, and that rubber grommets are in position.