

tel: 416-291-7371 1-800-565-8401  
fax: 416-291-8049 1-888-811-2264

web: www.vibro-acoustics.com  
eml: info@vibro-acoustics.com

File No.: INS-PSHB-004

Date: 16 Jun 2015

Supersedes: INS-PSHB-003

Date: 16 Nov 2011

Model shown with cut-away

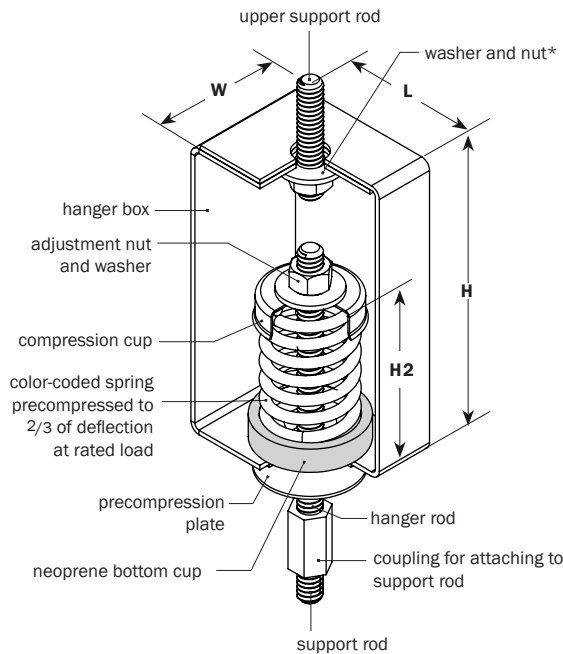

\* For upper support rods that are 5/8" diameter and smaller, use 5/8" USS wide washers at the housings. If smaller washers are needed, use wide washers (USS) and stack them. Washers by others.

**For Seismic Restraints Application Only**

fig. 1

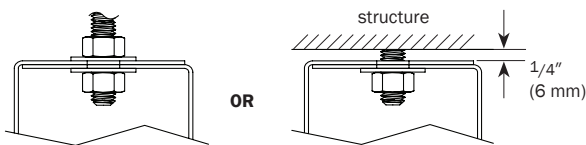
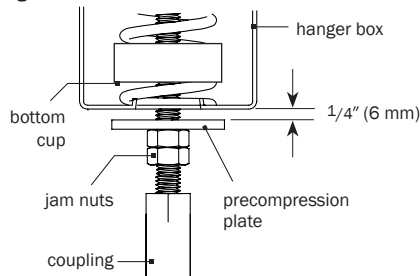

fig. 2



**INSTRUCTIONS**

**Option A: After system/equipment has been hung**

1. Hang all piping, ductwork, and equipment and bring to operating weight. Ensure sufficient space is left for hanger isolators to be installed.
2. Provide temporary support as required to allow support rods to be cut.
3. Cut support rods, removing an amount approximately equal to 1.5" plus the "H" dimension of the isolator being installed.
4. Properly locate each hanger in the submittal drawing using hanger model and spring color(s) as identification.
5. Install hangers, aligning rods in the center of each hole. Add washers, nuts and a coupling as appropriate. For seismic applications, add a second jam nut under the precompression plate and either add an additional nut and washer to lock the position of the box or locate within 1/4" of the structure (see fig. 1). The isolator may also be secured tight to the structure if desired.
6. Turn jam nut(s) as required to leave a 1/4" gap between the hanger box and the precompression plate. Continue maintaining this 1/4" gap while completing the installation.
7. Turn the adjustment nut until temporary supports can be easily removed. Do not overload hangers, however. Temporary supports may need to be left in place until further isolators are installed.
8. When adjusting isolators on a pipe run or equipment, be sure to load the hangers proportionally – an example of an adjustment sequence is shown below.
9. After adjustment is complete, be sure the support rod is not touching the hanger box at the lower hole, and the precompression plate clearance is 1/4" (fig. 2). For seismic applications, tighten two jam nuts under the precompression plate against each other.

**Option B: Before system/equipment is installed**

1. Properly locate each hanger in the submittal drawing using hanger model and spring color(s) as identification.
2. Attach precompressed spring hanger to a threaded rod support to structure. For seismic applications, add a second jam nut under the precompression plate and either add an additional nut and washer to lock the position of the box or locate within 1/4" of the structure (see fig. 1). The isolator may also be secured tight to the structure if desired.
3. Attach a coupling to the threaded rod supplied with the precompressed hanger and attach to equipment/pipe support rod.
4. Attach equipment or pipe to support rod being careful not to overload any one hanger. Provide temporary supports as required.
5. Bring equipment or pipe to its final operating weight before making any further adjustments.
6. Turn jam nut(s) as required to leave a 1/4" gap between the hanger box and the precompression plate. Continue maintaining this 1/4" gap while completing the installation.
7. Adjust the supported pipe or equipment level by turning the adjustment nut. Adjust the hangers proportionally following the sequence below as an example.
8. After adjustment is complete, be sure the support rod is not touching the hanger box at the lower hole, and the precompression plate clearance is 1/4" (fig. 2). For seismic applications, tighten two jam nuts under the precompression plate against each other.

**Isolator adjustment sequence example**

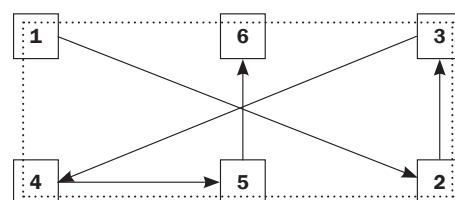

Isolator adjustment sequence is similar for other quantities and configurations.