

tel: 416-291-7371 1-800-565-8401
fax: 416-291-8049 1-888-811-2264

web: www.vibro-acoustics.com
eml: info@vibro-acoustics.com

File No.: INS-SCSR-006

Date: 22 Dec 2023

Supersedes: INS-SCSR-005

Date: 15 Sep 2023

INSTRUCTIONS

1. Handle the isolators with care and do not drop or hit as components may shift or come loose. Some models have precompressed springs and could present a hazard if damaged.

2. Properly locate each isolator as per the submittal drawing using the isolator model and spring color(s) as identification.
3. Elevate equipment enough to place spring isolators underneath and lower equipment onto isolators. Position the isolators to ensure load is centered on equipment support plate and that, if used, steel beam webs are located directly above the center rod. If isolators are to be bolted to the supporting structure locate bolt hole locations and make preparations as appropriate (drill holes and install anchor bolts). Leave shipping spacers in place.
4. For attachment to concrete structure, please refer to engineering calculations and follow the specification for concrete anchor. Edge distance, minimum anchor embedment, should be followed as specified.
5. For weld attachment of base plate to structure (if applicable), please refer to engineering calculation and welding procedure

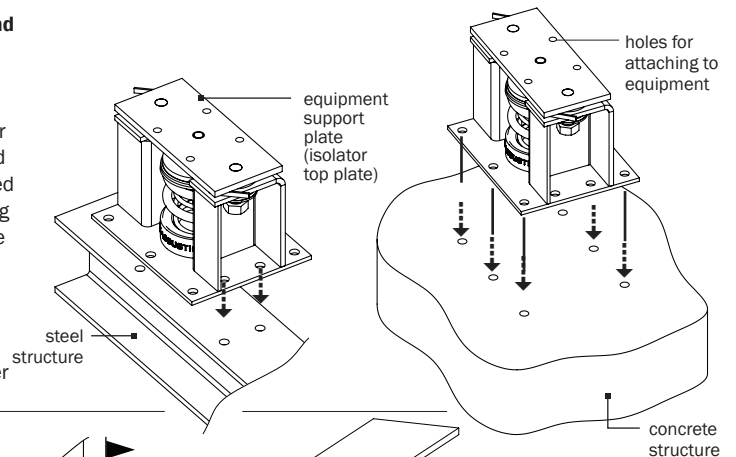

6. Attach equipment to equipment support plate (For example, by welding or bolts)

7. Piping and equipment must be at operating weight before final adjustment can begin.

bolts for attachment to equipment

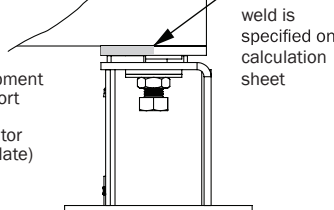
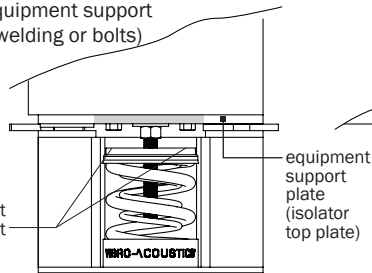

weld is specified on calculation sheet

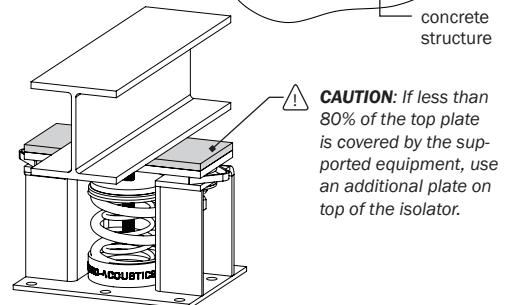

8. Back off the hold-down nuts until it locks with the limit bolt. *For pre-compressed isolators the 1/4" shim will come loose. Remove it.

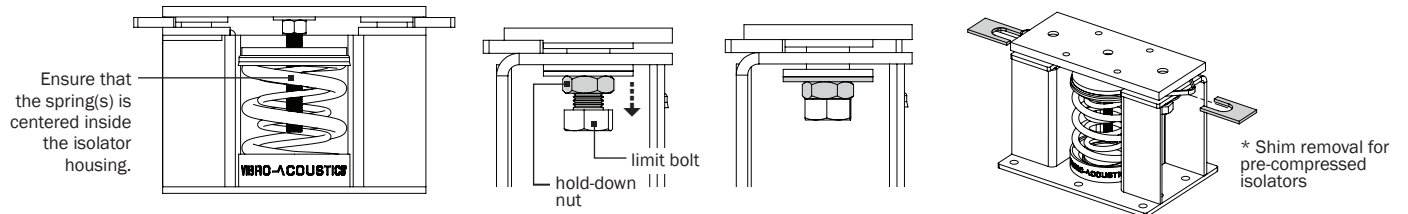

9. Turn spring adjustment nut counterclockwise 4 complete turns on each isolator as shown in the sequence below. Repeat this pattern until the top plate just lifts off the spacers on all isolators.

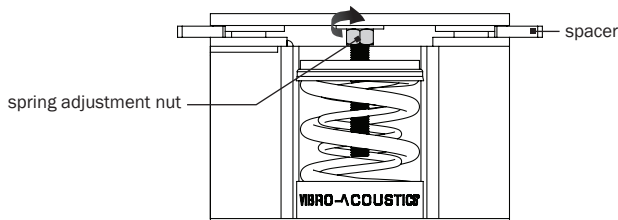

Isolator adjustment sequence example

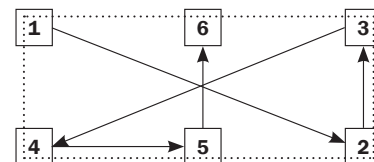

10. Remove all spacer pieces as soon as the top plate is lifted off the spacers. The spacers should slide out with no effort.

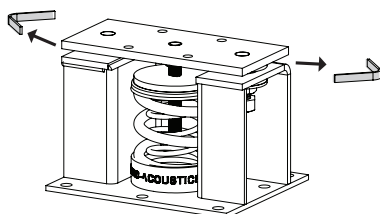

11. Ensure the restraint limit bolt is not touching the hold-down plate but is in the center of the hole, and that rubber grommets are in position.